

For Problems 1–2, find the value of x .

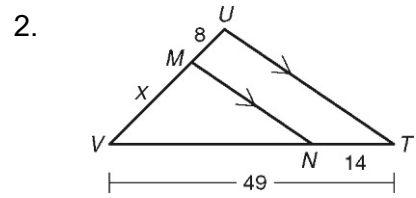

For Problem 3, determine whether the given segments are parallel.

3. \overline{WX} and \overline{DE}

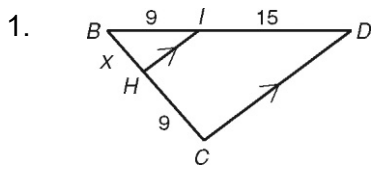
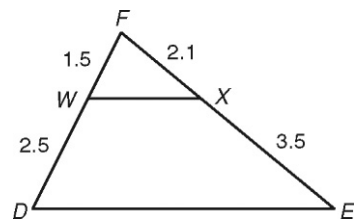

For Problems 4 – 6, answer the questions to find the length x .
The first one is done for you.

4. Based on the markings in the diagram, what do we know about \overline{RQ} and \overline{LM} ?

They are parallel lines.

5. What is the ratio of MS to QM ?

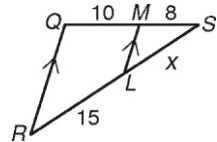

6. Solve for x .

Complete Problems 7 - 9 to determine whether $\overline{HY} \parallel \overline{XY}$

7. Find the ratio $\frac{JX}{XH}$

8. Find the ratio $\frac{JY}{YI}$

9. Is \overline{HI} parallel to \overline{XY} ? If so, why?

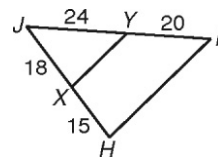

In Exercises 10 and 11, find the value of x for which $PQ \parallel RS$.

10.

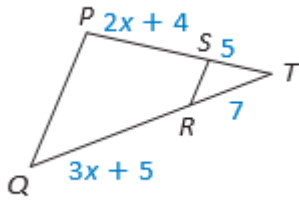

11.

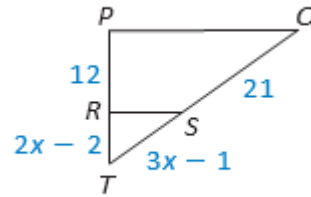

Use the diagram and the given information to find the unknown length.

12.

Given $\frac{CB}{BA} = \frac{DE}{EF}$, find BA .

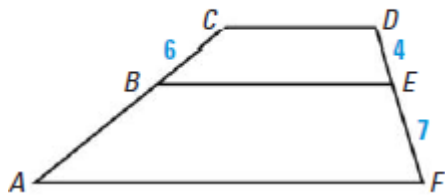

13.

Given $\frac{XW}{XV} = \frac{YW}{ZV}$, find ZV .

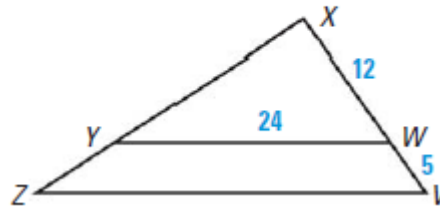

14.

Given $\frac{CA}{CB} = \frac{AE}{BD}$, find BD .

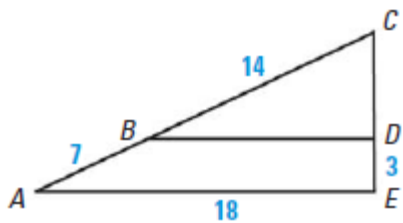

15.

Given $\frac{SQ}{SR} = \frac{TV}{TU}$, find RQ .

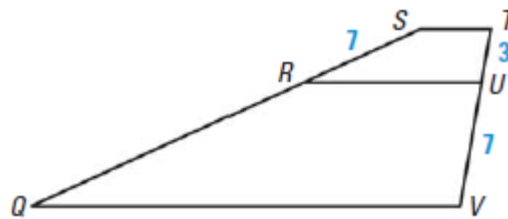

Refer to the figure for Problems 16–17. In the figure, \overline{PQ} represents the width of a lake. \overline{PQ} and \overline{ST} are parallel. The figure is not drawn to scale.

16. Suppose $PR = 45$ meters, $RT = 16$ meters, and $ST = 24$ meters. What is the width of the lake?

17. Suppose $QR = 52$ yards, $RS = 15$ yards, and $ST = 20$ yards. How wide is the lake?

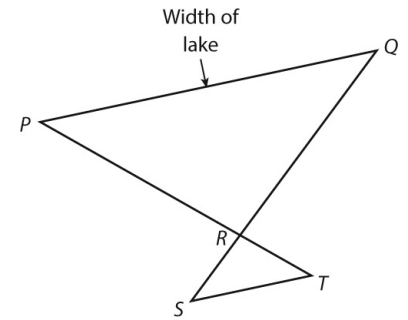

18. Jaden wants to build a bridge across a small stream on her farm. She drew this diagram and labeled it with measurements she made. How long will the bridge be?

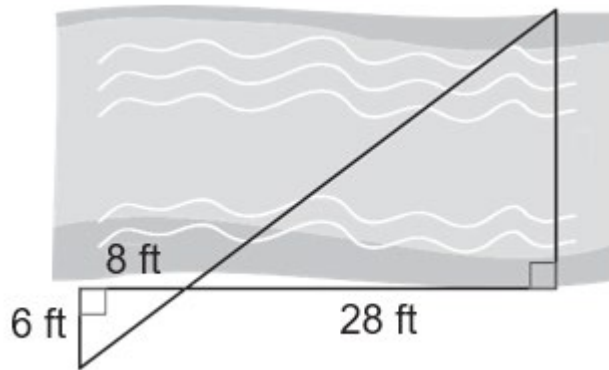

19. Luke is 6 feet tall and casts a shadow 15 feet long. At the same time, a tree casts a shadow 20 feet long. How tall is the tree?

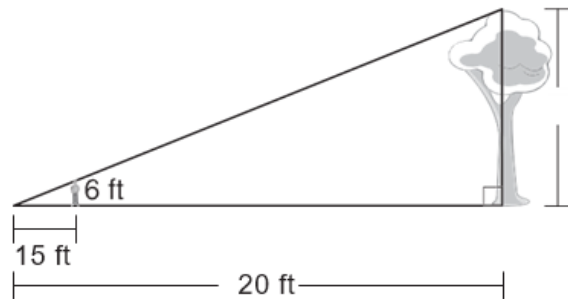

20. A 20-foot flagpole casts a shadow 32 feet long. The girl is 5 feet tall. How long is her shadow?

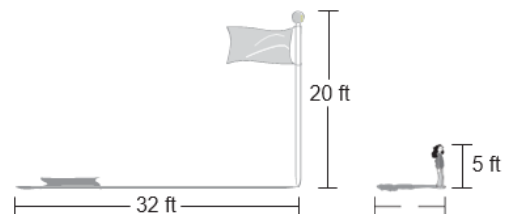

21. Kim places a mirror between herself and a flagpole. She stands so she can see the top of the flagpole in the mirror, creating similar triangles ABC and EDC . Her eye height is 5 feet and she is standing 6 feet from the mirror. If the mirror is 25 feet from the flagpole, how tall is the flagpole? Round to the nearest foot.

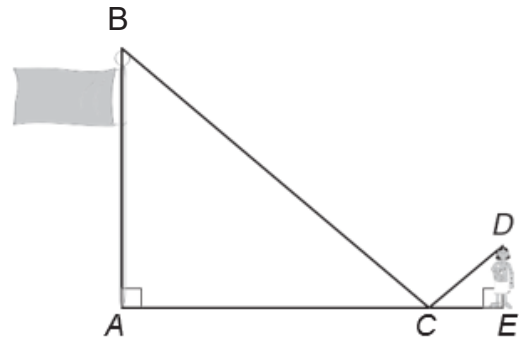

22. A warehouse is 120 feet tall and casts a shadow 288 feet long. At the same time, Paul casts a shadow 12 feet long. How tall is Paul?

Find the length of each segment.

3. \overline{KL}

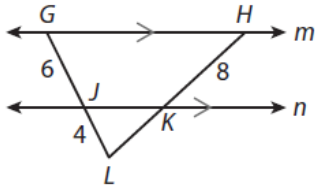

4. \overline{XZ}

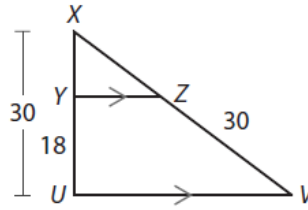

5. \overline{VM}

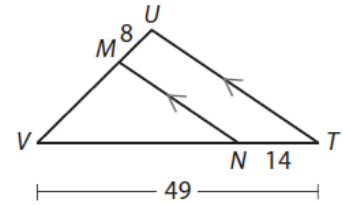

Show that the lines are parallel.

6. \overline{AB} and \overline{CD}

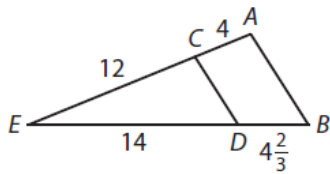

7. \overline{MN} and \overline{QR}

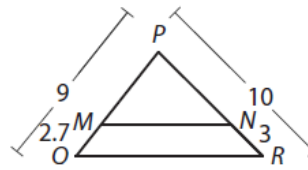

8. \overline{WX} and \overline{DE}

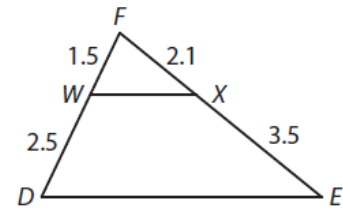

11. On the map, 5th Avenue, 6th Avenue, and 7th Avenue are parallel. What is the length of Main Street between 5th Avenue and 6th Avenue?

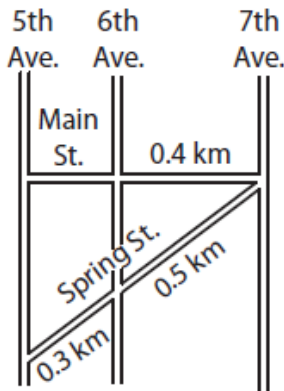

Use similar triangles $\triangle ABC$ and $\triangle XYZ$ to find the missing height h .

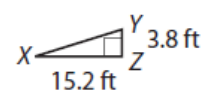
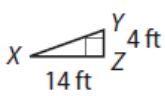
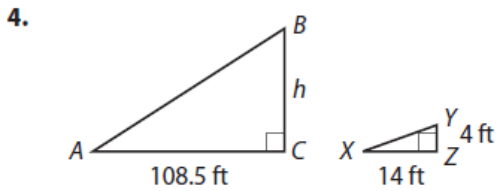
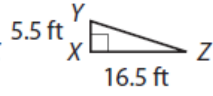
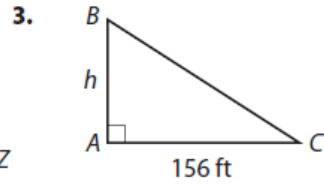
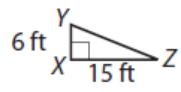
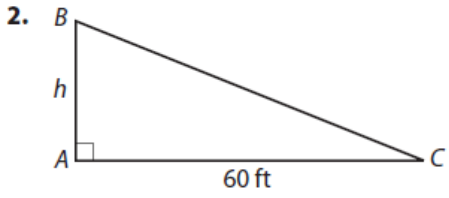

Use similar triangles $\triangle EFG$ and $\triangle IHG$ to find the missing distance d .

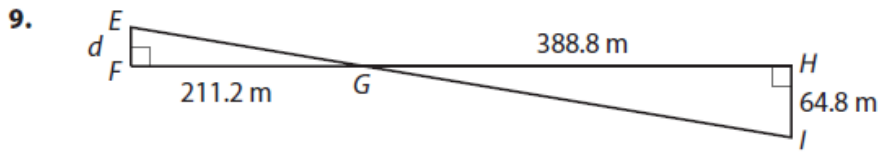
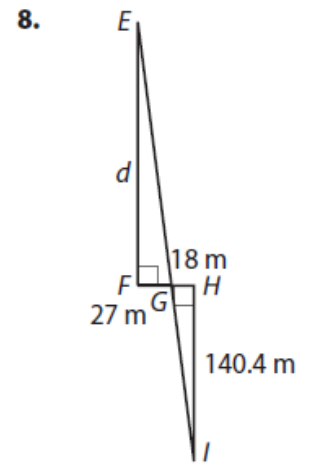
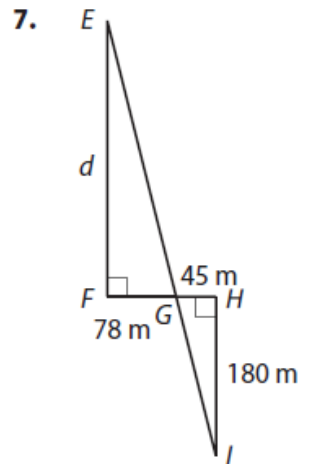
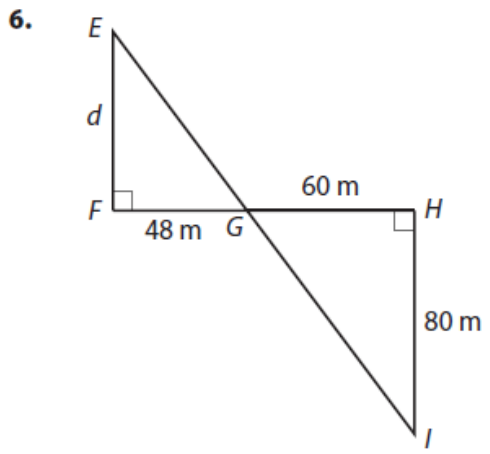

10. To find the height h of a dinosaur in a museum, Amir placed a mirror on the ground 40 feet from its base. Then he stepped back 4 feet so that he could see the top of the dinosaur in the mirror. Amir's eyes were approximately 5 feet 6 inches above the ground. What is the height of the dinosaur?

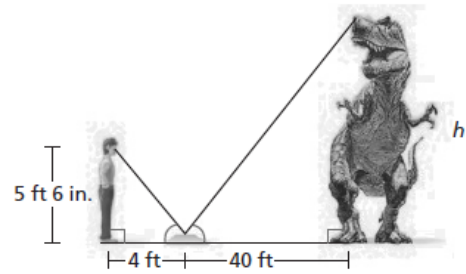

18. In order to find the height of a cliff, you stand at the bottom of the cliff, walk 60 feet from the base, and place a mirror on the ground. Then you face the cliff and step back 5 feet so that you can see the top of the cliff in the mirror. Assuming your eyes are 6 feet above the ground, explain how to use this information to find the height of the cliff. (The angles marked congruent are congruent because of the nature of the reflection of light in a mirror.)

